

# ➤ H4b (L4b) hard shoulder

## H4bBL500

### components

- Upper W beam 4000 mm th. 5,0 mm;
- Lower 3W beam 4000 mm th. 2,5 mm;
- "C" Section Post 30x80x120 th. 5,0" mm  
H =2100 mm c/c 1000 mm;
- "U" shape Spacer for lower 3W beam;
- Intermediate proof little plate;
- Stiffener for "C" Post
- Bolt and Nuts;
- Reflector (n° 1 every 8,00 m).

This Barrier provides, for each section of barrier, the installation of Approach/Escape section modules for a total length of 16,00 lm (8,00 for Approach + 8,00 for Escape)

### section

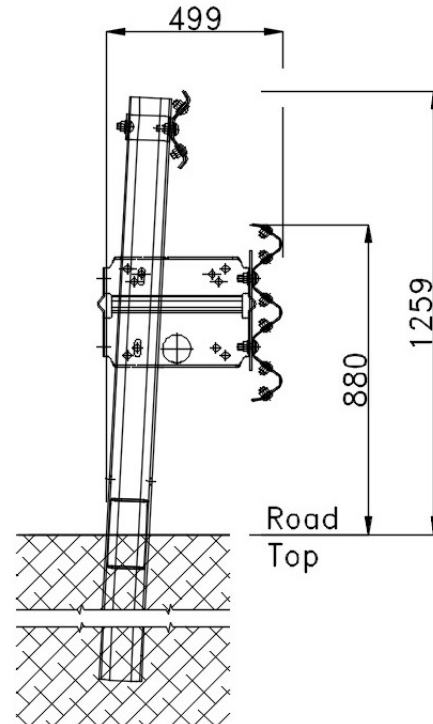

- Dwg. n.: H4bBL500  
c/c distance between posts: 1.000 mm

### performance

TB11 – Car 900 kg

Test: 2008

ASl: A

TB32 – Car 1.500 kg

Test: 2009

ASl: A

TB81 - Truck 38.000 kg

Test: 2007

W<sub>N</sub>: m 1,0 (W3)

D<sub>N</sub>: m 0,8

V<sub>N</sub>: m 1,3 (VI4)

### FRONTAL VIEW

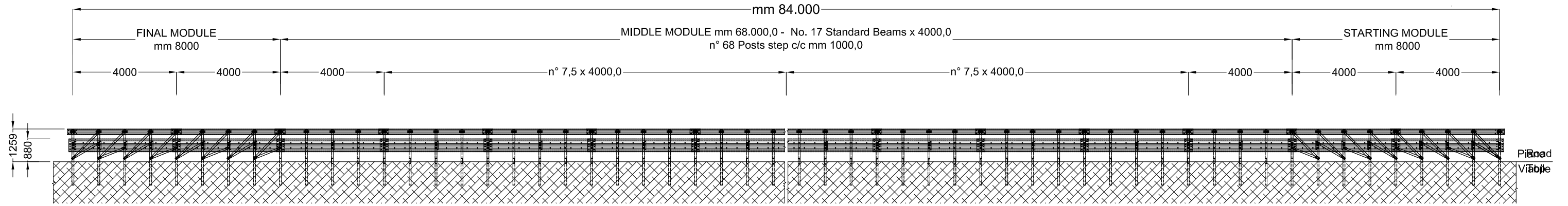

← TRAFFIC DIRECTION (Impact on the Right)

