

>> H2 (L2) bridge barrier

H2BP500

components

- W beam 5333 mm th. 3,0 mm
- Post "HEA100" H = 727 mm with base plate; c/c mm 2133,3
- Spacer th. 5,0 mm for two wave beam
- Unthreading proof little plate
- Flat upper and lower diagonal 70 x 5 mm
- Special intermediate plate 240 x 140 mm
- Bolts and nuts
- Reflectors (1 every 10,66 lm)

section

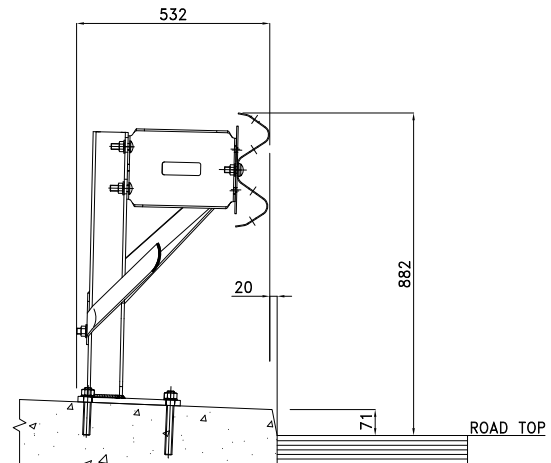

- **Dwg. n.: H2BP500**
c/c distance between posts: **2.133 mm**

performance

TB11 – Car 900 kg
Test: IME 16005_V1
ASl: A

TB32 – Car 1.500 kg
Test: IME 16006
ASl: B

TB51 - Bus 13.000 kg
Test: IME 16004_V1
W_N: m 0,9 (W3)
D_N: m 0,6
V_{I_N}: m 1,3 (VI4)

FRONT VIEW

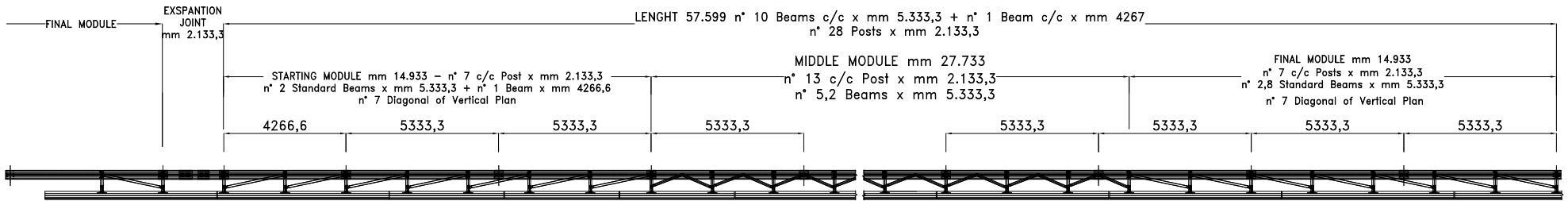

TRAFFIC DIRECTION (Impact on the Left) →

TOP VIEW

