

# >> H1 bridge barrier

## H1BP100

### components

- W beam 5333 mm th. 2,5 mm
- Post "HEA100" H = 727 mm with base plate; c/c mm 3199,9
- Spacer th. 5,0 mm for two wave beam
- Unthreading proof little plate
- Flat upper and lower diagonal 70 x 5 mm
- Bolts and nuts
- Reflectors (1 every 10,66 lm)

### section

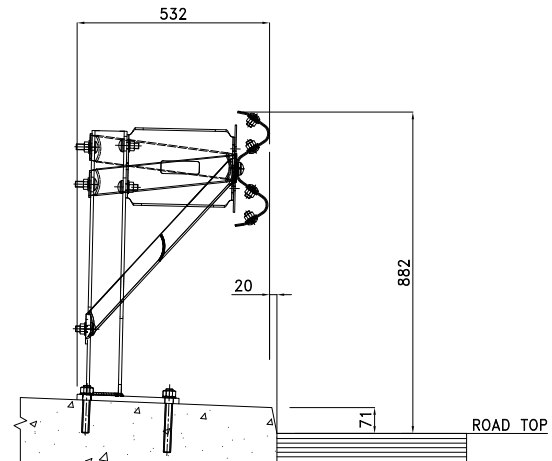

- **Dwg. n.: H1BP100**  
c/c distance between posts: **3.199 mm**

### performance

TB11 – Car 900 kg  
Test: IME 16008  
ASl: A

TB42 - Truck 10.000 kg  
Test: IME 16007  
W<sub>N</sub>: m 1,0 (W3)  
D<sub>N</sub>: m 0,5  
V<sub>N</sub>: m 1,4 (VI5)

FRONT VIEW

